

Plate Heat Exchanger AF250 Series

AF252 & AF253



SonFlow offers a wide range of AHRI-certified® products, including the AF250 series. The series is certified in the category of "AHRI Liquid to Liquid Heat Exchangers," which confirms the thermal performance according to the specified specifications. With the AF250 series, SonFlow offers a reliable and efficient single-pass solution that is suitable for many different applications. This is a cost-effective solution that ensures optimal heat transfer and minimal maintenance.

Typical applications:

- Heat recovery
- HVAC
- Geothermal
- Industrial
- Marine
- Chemicals
- Sugar industry
- Mining
- Electronics

- Gentle product handling
- Design pressure up to 25 bar
- Operating temperature up to 180° C
- Leak chamber
- Fixed bolt head
- Lifting lug
- Lining
- Lock washer

Features:

Every detail is carefully designed to ensure optimal performance, reduced maintenance costs and decreased downtime:

- Compact design
- High flexibility
- Lock gasket system

Benefits:

- Lower operating costs
- Cost-effective
- Easy assembly
- Increased energy efficiency
- Easy cleaning
- Dead spots, that cause corrosion and fouling are eliminated

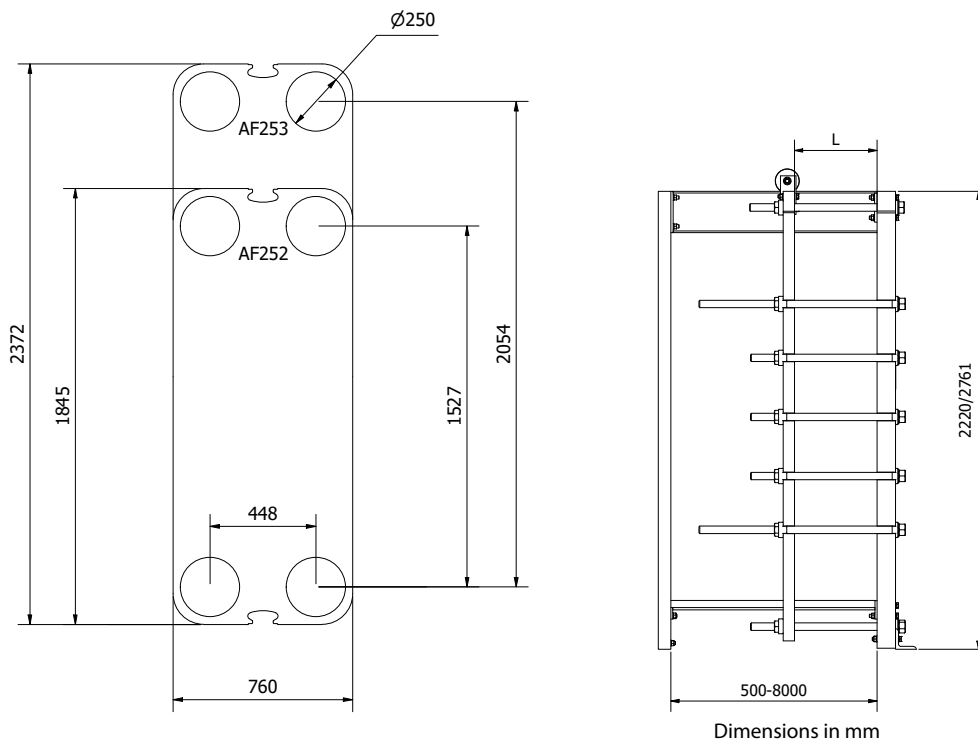

Dimensions in mm

Design pressure:

- Painted frames: 0.6/1.0/1.6/2.5 MPa (87/145/232/362 PSI)

Construction standards:

- EN13445
- ASME sec VIII, Div. 1

Frame:

- Painted frame, RAL 5010 (available in other colours)

Connections:

- DN 250/10" flange in carbon steel, rubber lined or clad with AISI 316 or titanium
- According to all known standards

Plate material:

- AISI 304/316 and titanium
- Other materials available on request

Gaskets:

- Click on gasket – a glue less system for sealing
- Materials: NBR, EPDM and Viton
- Other materials available on request

Accessories:

- Drip tray
- Insulation jackets
- Safety cover
- Assembling spanner
- Foundation feet



AHRI Certified® is the trusted mark of performance for heating, air conditioning, water heating, and commercial refrigeration equipment. To find AHRI Certified products, go to www.ahrirectory.org.

Certificerede produkter i the AF250 Series

Model number	AHRI Certified Reference Number
AF252PL16	207615040
AF252PL25	207615041
AF253PL10	207615042
AF253PL16	207615043
AF253PL25	207615044